



Pic. 1



Pic. 2



Pic. 3



Pic. 4

**MOUNTING AND MAINTENANCE**

The connection system on bracket, allows to install the luminaire parallel to the ground.

See the bracket mounting instruction for particular fixing on bracket.

To gain access to the electrical parts loosen the 8MA x 50 screw (A) [Pic. 1] placed on the lower ring using a set screw wrench of 5mm. The lower ring will open [Pic. 2].

To connect the luminaire to the electrical line, fix the cable to the on-load switch.

The feeding of the fitting must be done with a bipolar cable with nominal diameter between 7mm to 13mm.

To change the lamp unlock the screw (B) [Pic. 3] and lift the reflector.

The reflector has been projected to function without incline the fitting.

The reflector can be placed in 3 different positions in order to adapt the photometrical solid to the road width (C) [Pic. 4].

To close the luminaire screw the 8MA x 50 screw (A) [Pic. 1]. Tighten the screw with a set screw wrench of 5mm applying a twisting moment of 8Nm.







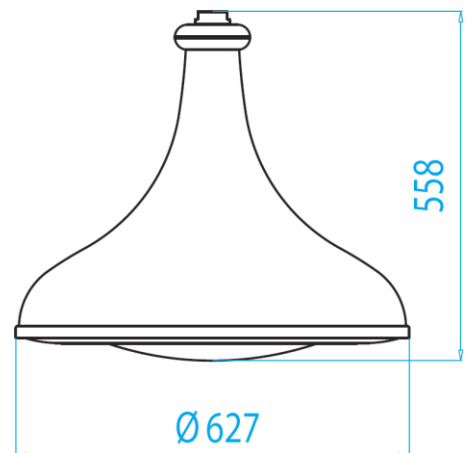

Suggested height of installation		
Power [W]	H min [m]	H max [m]
70	4	7
100	5	8
150	6	10
250	7	12

**Dimensions**



**Lamp type - Weight**

Model	Lamp type							Weight [gr]	
								Empty	Control Gear
GOBLET	80 W	70 W	70 W	70 W	70 W	-	-	9.000	11.000
	125 W	100 W	100 W	100 W	100 W	-	-		11.500
	-	150 W	150 W	150 W	150 W	-	-		12.000
	-	250 W	250 W	250 W	250 W	-	-		13.000
GOBLET OC	80 W	70 W	70 W	70 W	70 W	-	-	9.500	11.500
	125 W	100 W	100 W	100 W	100 W	-	-		12.000
	-	150 W	150 W	150 W	150 W	-	-		12.500
GOBLET OP	-	-	-	-	-	150 W	150 W	9.500	12.500
	-	-	-	-	-	250 W	250 W		13.500

**INFORMATION TO THE CUSTOMERS**

 **Directive 2002/96/EC (Waste Electrical and Electronic Equipment - WEEE): information for users.**

This product complies with EU Directive 2002/95/EC. The crossed-out wastebasket symbol on the appliance means that at the end of its useful lifespan, the product must be disposed of separately from ordinary household wastes. The user is responsible for delivering the appliance to an appropriate collection facility at the end of its useful lifespan. Appropriate separate collection to permit recycling, treatment and environmentally compatible disposal helps prevent negative impact on the environment and human health and promotes recycling of the materials making up the product. For more information on available collection facilities, contact your local waste collection service.

**ELECTRICAL LINE CONNECTION**

In order to insure double insulation characteristic of the feeder cable, we would advise that you first secure the feeder cable to the internal cable clamp, remove approximately 25mm of external sheathing, and 6mm of sheathing from the internal wires.

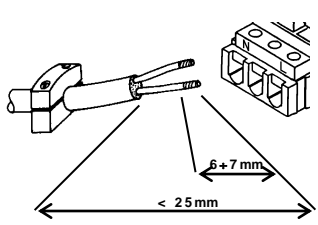

**GOBLET**

**Side area**  $0.15 \text{ m}^2$

**Base area**  $0.31 \text{ m}^2$

**Form factor: 1.2**

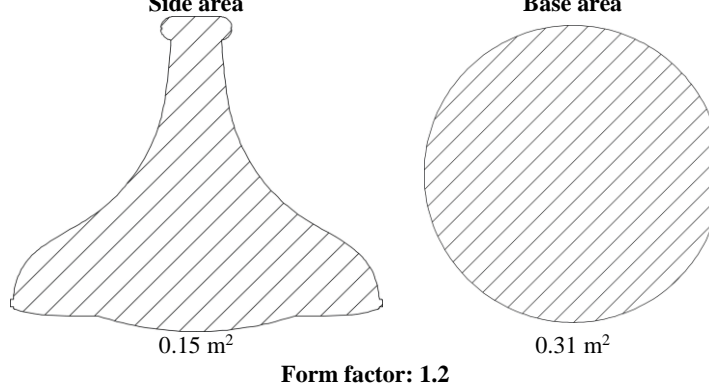

**WIRING SCHEME**

80 W ÷ 125W MBF      70 W ÷ 250W SHP/MHL 

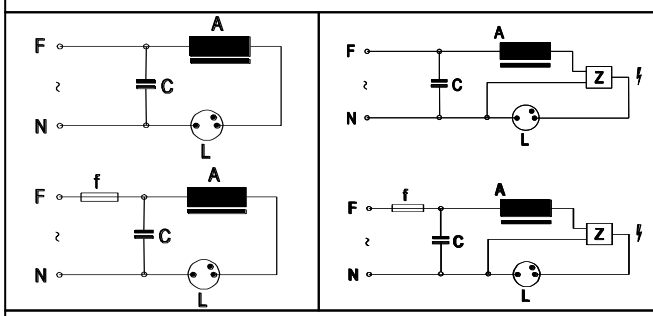

**A** – Ballast      **L** – Lamp      **f** – Fuse  
**C** – Condensatore      **Z** – Accenditore

**ATTENTION**



- Class II luminaires must be installed in such a way that it is impossible for any exposed metal part to come in contact with electrical components.
- Luminaires for Metal Halide lamps must be always complete with its protective screen.
- For luminaires with Metal Halide lamps, damaged protective shields can only be replaced with original AEC Illuminazione's replacement shields.
- On luminaires for Metal Halide lamps use only UV Stop protected lamps.
- This luminaire has been designed and manufactured following all relevant standards. The installation must be done by experienced personnel and following the instructions.
- The present instruction paper has to be kept for any future maintenance operation on the luminaire.
- Non compliance with the above will automatically release AEC Illuminazione Srl from any responsibility.

# MOUNTING AND MAINTENANCE INSTRUCTION

# GOBLET

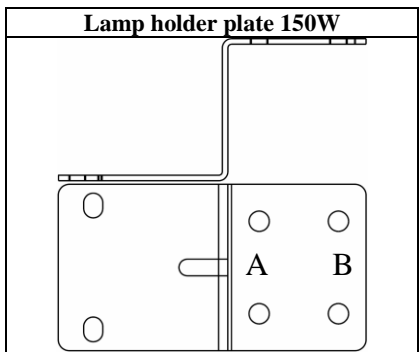
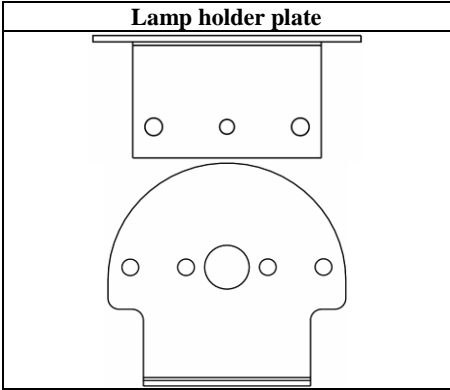
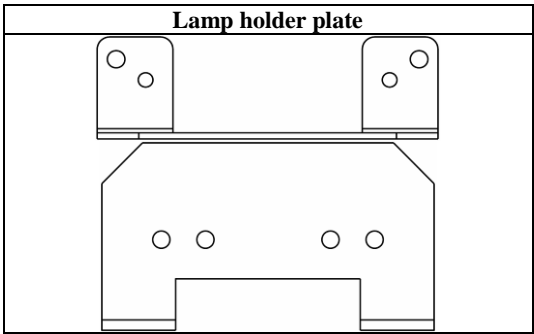

Lamp positions GOBLET ST Optic	
250SHP-T	POS 3 DIR
250SHP-E, MHL-E, MBF	
150SHP-E, 250E MHL-T	
100W, 150SHP-T	POS 4 DIR
100SHP-E	POS 5 DIR
125MBF	POS 4 ROV
70SHP-T	POS 5 ROV
80MBF, 70SHP-E	POS 6 ROV
70, 100, 150MHL-E	

Lamp positions GOBLET OC Optic	
125W MBF	B Dir
70W SHP-T with ignitor	C Dir
150, 100, 70W MHL-E	D Dir
80W MBF	
70W SHP-E without ignitor	
E/27 Empty	A Rov
150W SHP-E	
150W SHP-T, 100W SHP-T	C Rov
E/40 Empty	D Rov
100W SHP-E	

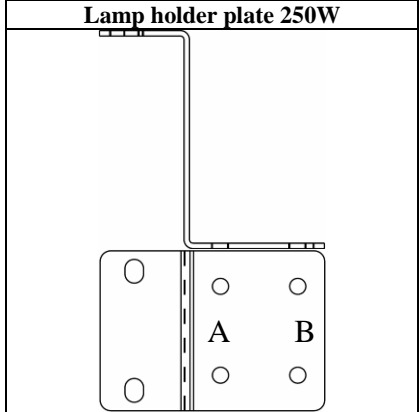

Lamp positions GOBLET OP Optic	
150W MHL-TS, SHP-TS	A
250W SHP-TS	A
250W MHL-TS	B

